

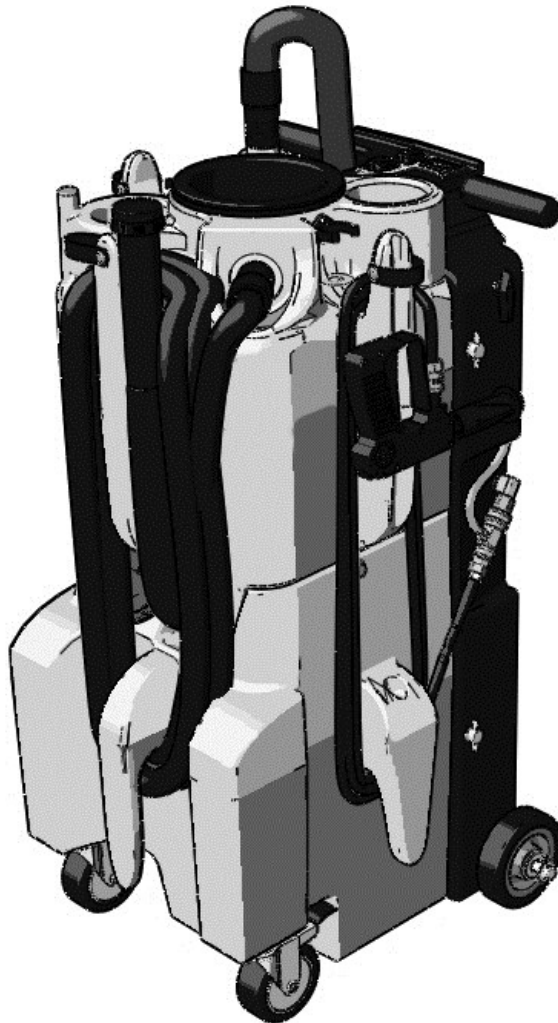

Operator & Parts Manual

KaiVac[®] 1200 Series

1215 Serial Number 415- 1250 Serial Number 3309-
CE1250 215-



Revision Sheet

Release No.	Date	Revision Description
101413	10/14/13	Operator & Parts Manual Released
121713	12/17/13	Modified Rotomold Warranty to 5 years.

NOTE: Specifications and parts are subject to change without notice

Kaivac, Inc.

401 S. Third Street
 Hamilton, OH 45011

OPERATOR & PARTS MANUAL

	<u>Page #</u>
1.0 GETTING STARTED	1-1
1.1 Limited Warranty Protection Plan	1-1
1.2 Warranty Registration Form.....	1-2
1.3 Safety Precautions	1-3
2.0 OPERATION.....	2-1
2.1 Out-of-Box Setup Instructions.....	2-1
2.2 Kaivac Tool Arrangement	2-2
2.3 Preparing Your Kaivac For Use	2-3
2.4 1200 Series Vac Tank Horn Operation	2-4
2.5 Operating your Kaivac using S-I-M-P-L-E Process	2-5
3.0 MAINTENANCE.....	3-1
3.1 Maintenance.....	3-1
3.2 Squeegee Head Maintenance	3-2
3.3 Black Box Removal Instructions	3-3
3.4 Troubleshooting.....	3-4
3.5 Machine Diagrams.....	3-7
3.6 Parts List	3-19

1.0 GETTING STARTED

1.1 Limited Warranty Protection Plan

The Kaivac has been engineered and tested to provide long lasting performance. This warranty covers defects in workmanship or materials under normal use and service from the date of purchase.

Kaivac, Inc. warrants the following components to be free from defects in materials and workmanship for these time periods:

- 1.) Extended Warranty for end users who use only Kaivac chemicals for the life of the machine.
 - ◆ 5 years on rotationally molded parts
 - ◆ 3 years on other parts (excluding wear items)
 - ◆ 1 year on labor
- 2.) Standard Warranty (for approved non-Kaivac chemicals)
 - ◆ 1 year parts and labor
- 3.) Chemicals that have not been approved by Kaivac (If uncertain, please contact Kaivac to verify your chemical before using).
 - ◆ No warranty

All Kaivac replacement parts are guaranteed for 90 days from the date of installation. Normal wear items such as wheels, hoses, seals, gaskets, cords, casters, squeegees and GFCl are excluded from warranty coverage.

All warranty claims must be accompanied by a Return Authorization Number (RAN), which is available by calling the Kaivac, Inc. Customer Service Department. No returns will be accepted without a RAN.

This warranty does not apply to return freight costs, damage or defect caused by accident, negligence, misuse, fire or repair done by anyone other than a Kaivac authorized repair center. In no event shall Kaivac, Inc. be liable for incidental or consequential damages, or any damages to persons or property.

Please Note: Under no circumstances will the seller be liable for any loss, damage, expenses or consequential damages arising in connection with the use or inability to use seller's product. Kaivac, Inc. reserves the right to make changes or improvements to its equipment without notice. Some states do not allow the exclusion or limitation of incidental or consequential damages. This warranty is in lieu of any other warranty expressed or implied, including any warranty of merchantability or fitness for a particular purpose.

1.2 WARRANTY REGISTRATION FORM

To be completed and mailed or faxed by the customer purchasing equipment. Return this warranty card within ten days of purchase.

Purchased By:

Name: _____ Title: _____

Company: _____

Street Address: _____

City: _____ State: _____ Zip Code: _____

- | | | | |
|---------------------------------|---------------------------------|---|--|
| <input type="checkbox"/> KV1750 | <input type="checkbox"/> KV1250 | <input type="checkbox"/> KV2150 | <input type="checkbox"/> KV1715AC |
| <input type="checkbox"/> KV1715 | <input type="checkbox"/> KV1215 | <input type="checkbox"/> OMNIFLEX
Pump Box | <input type="checkbox"/> OMNIFLEX
Wet/Dry Vac |

Serial Number: _____

Type of Business

- | | | |
|---|---|---------------------------------------|
| <input type="checkbox"/> School/University | <input type="checkbox"/> Contract Cleaner | <input type="checkbox"/> Office |
| <input type="checkbox"/> Hospital/Health Care | <input type="checkbox"/> Industrial | <input type="checkbox"/> Other: _____ |

Intended Uses (check all that apply)

- | | | |
|--|---|---|
| <input type="checkbox"/> Restroom Cleaning | <input type="checkbox"/> Cleaning Around Machines | <input type="checkbox"/> Classroom Cleaning |
| <input type="checkbox"/> Floor Stripping | <input type="checkbox"/> Stairwell Cleaning | <input type="checkbox"/> Other: _____ |
| <input type="checkbox"/> Kitchen Cleaning | <input type="checkbox"/> Lockers & Showers | <input type="checkbox"/> |
| <input type="checkbox"/> Carpet Extraction | <input type="checkbox"/> Hallway Cleaning | <input type="checkbox"/> |

Thank you for registering for our warranty program.

Please return completed forms to:

Kaivac, Inc.
401 S. Third Street
Hamilton, OH 45011
Or Fax to: (513) 887-4601



1.3 SAFETY PRECAUTIONS

IMPORTANT SAFETY INSTRUCTIONS—SAVE THESE INSTRUCTIONS

CAUTION: To reduce the risk of injury, read operating instructions carefully before using.

 **WARNING:** Risk of injection or injury to persons – do not direct discharge stream at persons.

 **WARNING RISK OF ELECTROCUTION:** 

- ◆ Connect to a properly grounded outlet. Do not remove ground pin.
- ◆ Inspect cord before using – do not use if cord is damaged.
- ◆ Keep all connections dry and off the ground.
- ◆ Do not touch plug with wet hands.
- ◆ This product is provided with a ground fault circuit interrupter built into the power cord. If replacement of the plug or cord is needed, use only identical replacement parts.
- ◆ Test the ground fault circuit interrupter (GFCI) before each use.
- ◆ Do not close a door on the cord or pull the cord around sharp edges or corners.
- ◆ Keep the cord away from heated surfaces.
- ◆ Do not spray liquid from the Kaivac onto electrical outlets or on any electrical devices.
- ◆ Turn off the unit before unplugging.
- ◆ Do not pull on the cord to unplug. Grasp the plug at the outlet and pull.

Grounding Instructions:

THE KAIVAC MUST BE GROUNDED. If it should malfunction or stop working, grounding provides a path of least resistance for the electrical current and reduces the risk of electrical shock. The Kaivac is equipped with a ground fault circuit interrupter (GFCI) to further reduce danger and risk of electric shock. It must be maintained and tested regularly. An equipment grounding cord and plug is included with the unit. Cutting off the ground wire or using a cord with an ungrounded plug will void the warranty on the Kaivac.

Improper connection of the equipment grounding cord can result in the risk of electrical shock. Ask a qualified electrician or service person to check the outlet grounding if you are unsure. Do not modify the plug provided with the Kaivac. If it will not fit into the outlet, have a properly grounded outlet installed by a qualified electrician.

 **WARNING:** When using this product, basic precautions should always be followed, including the following:

- ◆ Read all the instructions before using the product.
- ◆ To reduce the risk of injury, close supervision is necessary when a product is used near children.
- ◆ Know how to stop the product and bleed pressures quickly. Be thoroughly familiar with the controls.
- ◆ Stay alert – watch what you are doing.
- ◆ Do not operate the product when fatigued or under the influence of alcohol or drugs.
- ◆ Keep operating area clear of all persons.
- ◆ Do not overreach or stand on unstable support. Keep good footing and balance at all times.
- ◆ Do not use to pick up flammable or combustible materials.
- ◆ Follow the maintenance instructions specified in the manual.

Personal Protective Equipment (PPE): It is recommended to wear proper personal protective equipment as required by the chemical product label instructions used in conjunction with the Kaivac.

FOR INDOOR USE ONLY

2.1 OUT-OF-BOX SETUP INSTRUCTIONS

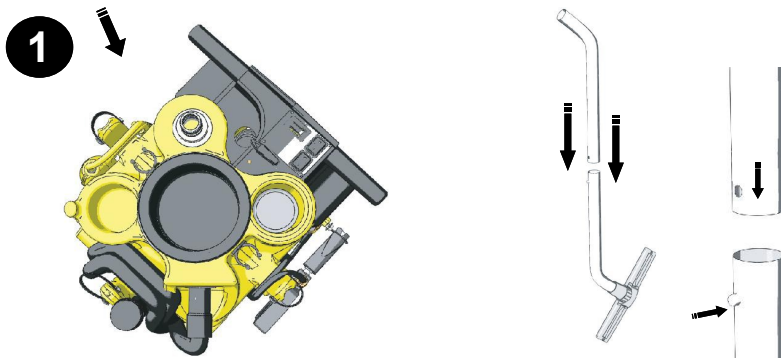

Remove vac wand sections from the accessory box and attach together until locking pin engages as shown

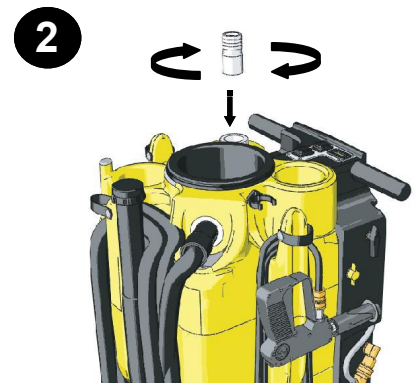

After removing machine from container, attach the plastic elbow to the vac tank as shown above

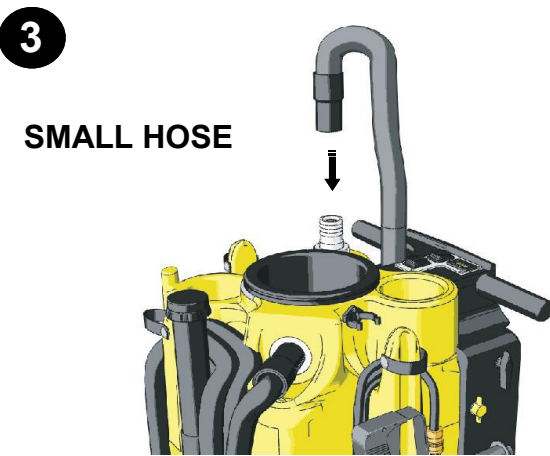

SMALL HOSE

Attach vac motor hose to barb and vac motor inlet as shown above

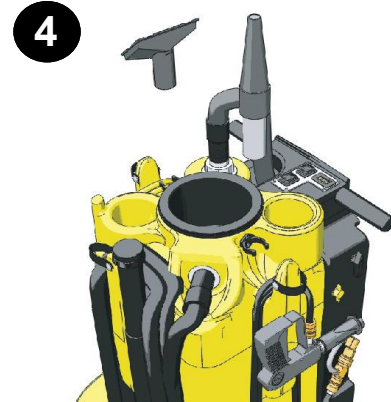

Remove the tools and hoses from the accessory box and place them in the appropriate locations as shown above. Place extra tools in tote bag and hang bag over nose of machine.

5 Remove the Vacuum Hoses from the Accessory Box. Assemble as shown.

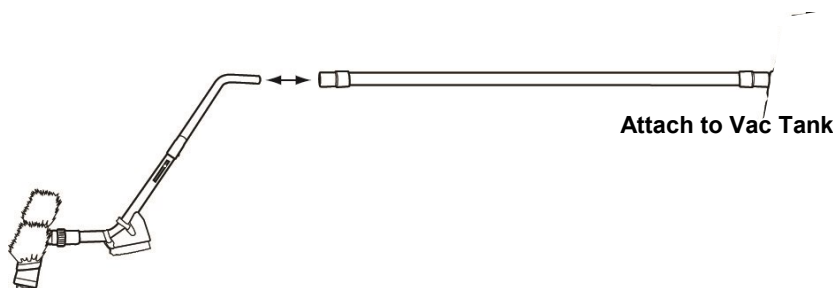

2.2 KAIIVAC TOOL ARRANGEMENT

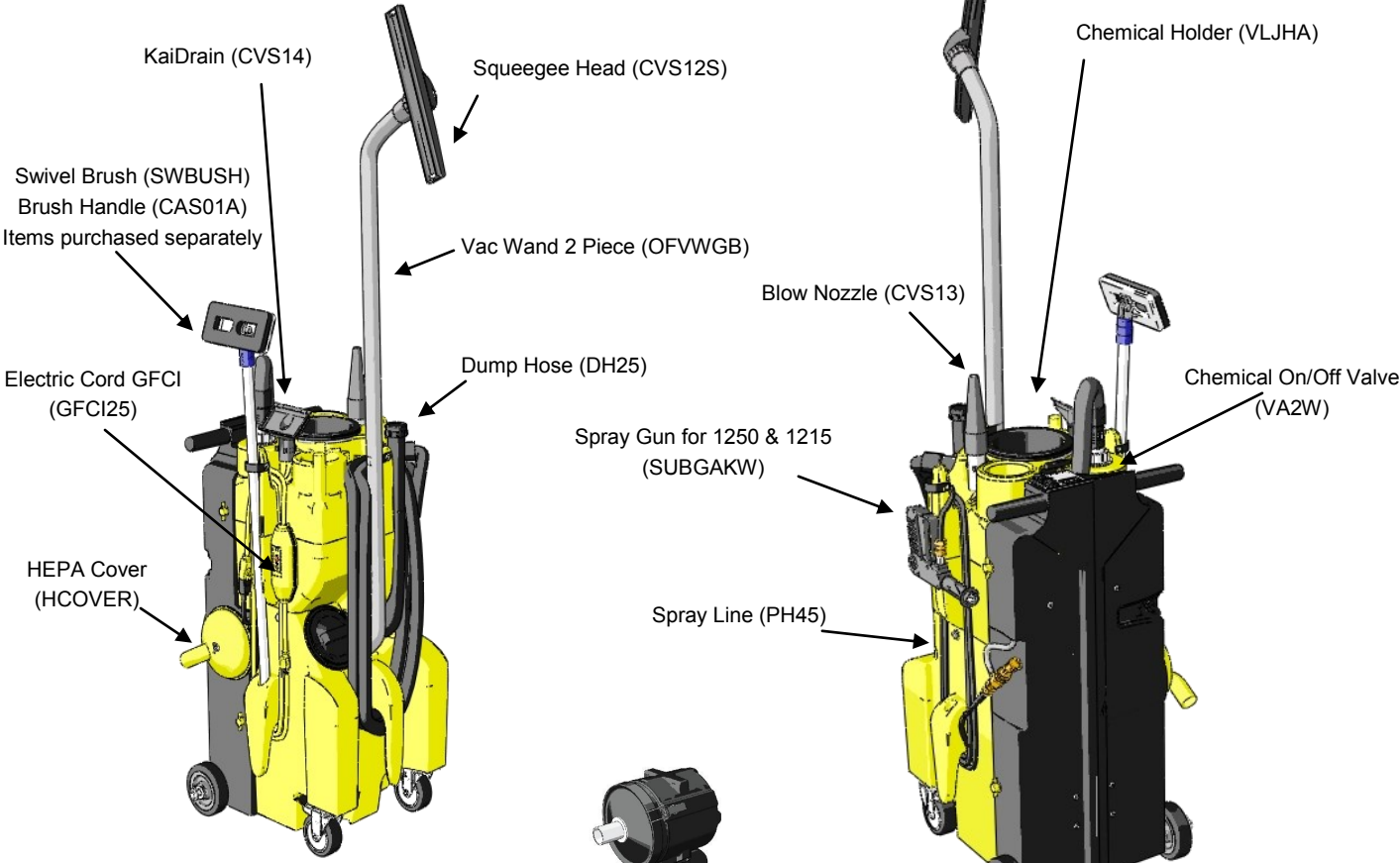

Front Right View

Rear Left View

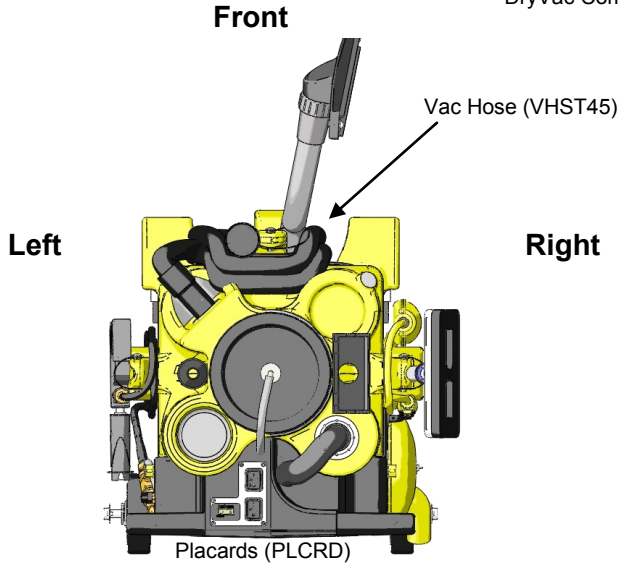
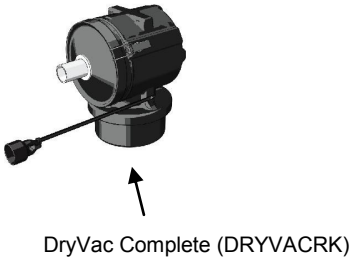



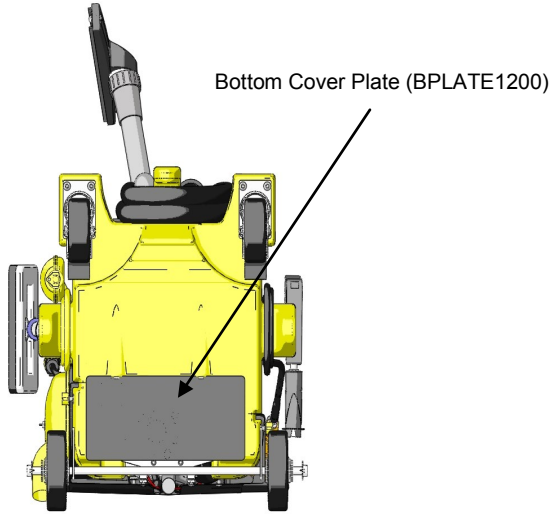

Overhead View

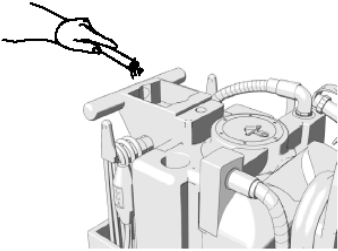

Bottom View

2.3 PREPARING YOUR KAIIVAC FOR USE

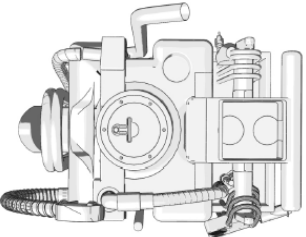
*Applicable to all units, but KV1700 Series shown for illustration

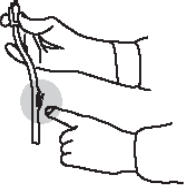
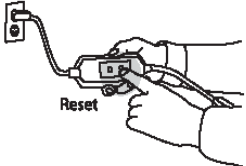
<p>1. Fill machine with clean, cool water.</p>	
<p>2. Prepare the cleaning solution you will be using by attaching the chemical feed line and cap to the top of your chemical bottle and selecting the proper metering tip. (See placard for metering tip information)</p>	
<p>3. Check machine for all tools and supplies needed to complete task. See "Tool Arrangement" in Section 2.2 of this manual.</p>	
<p>4. If using a cleaning product that has high foaming use a foam inhibitor to cut down on foam. Pour 2 capfuls of inhibitor in the vac hose with vac running to coat inside of hose.</p>	
<p>5. Check all hoses and spray lines for damage prior to use. If damage is found, do not continue until proper repairs are completed.</p>	
<p>6. Plug in machine and test GFCI (Ground Fault Circuit Interrupter) to ensure it is working properly. You are now ready.</p>	

2.4 1200 SERIES VAC TANK HORN OPERATION

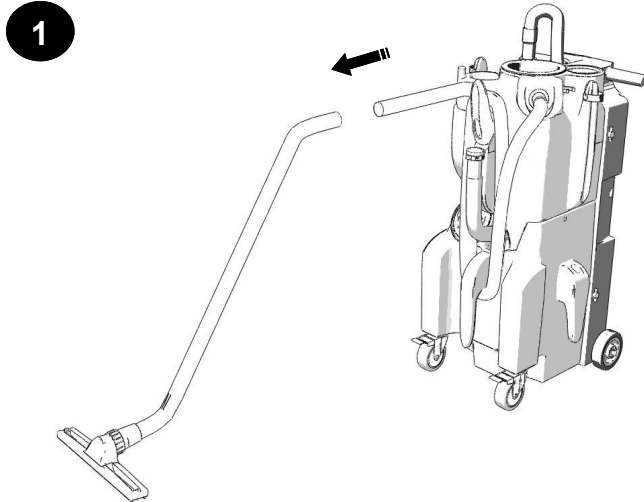

1
Connect the vacuum wand and slinky hose together

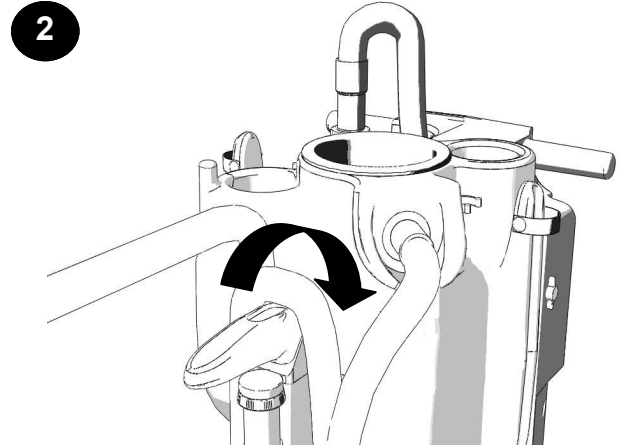

2
Rotate the horn assembly so that it is now pointing towards the front of the machine.

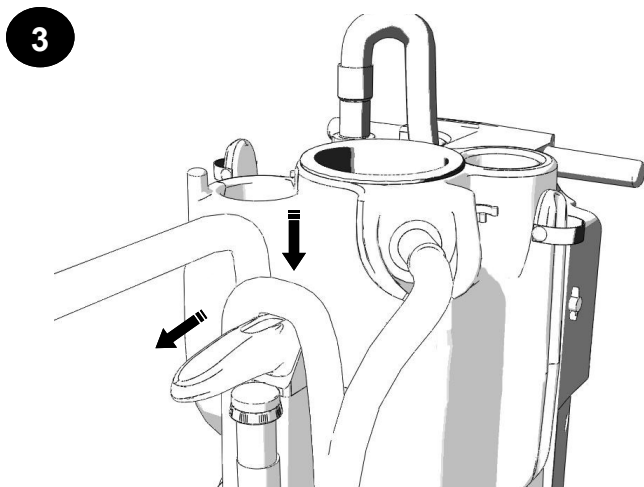

3
Place hand behind vac hose and slide forward off of horn onto floor.

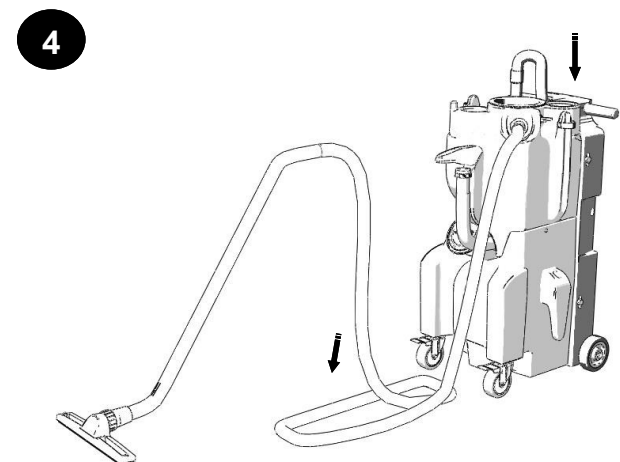

4
Once hose is off and on floor turn on vac motor and proceed extracting.

2.5 S.I.M.P.L.E PROCESS

*Applicable to all units, KV1700 Series shown for illustration.

Set-up

Fill with clean, cool water

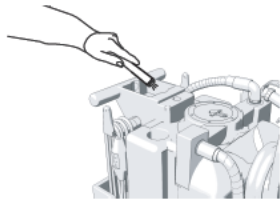

Add 1 cap of KaiDri (for spot-free rinsing)

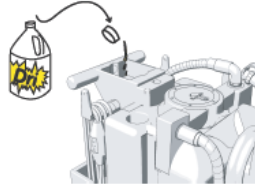

Select metering tip and insert into cap barb



Inject

Chemicals

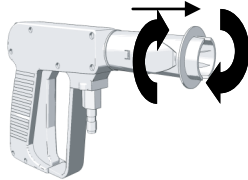

Fan Spray

LOW Pressure Mode



Fan Spray

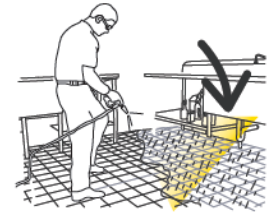

Manual

Brush



Manually brush heavily soiled areas



Pressure wash and rinse

Fresh Water

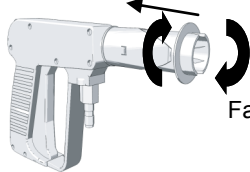

Fan

HIGH Pressure Mode

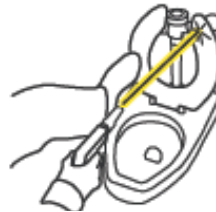

Loop

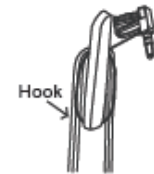

Adjust last loop (if needed)

Extract



3.1 MACHINE MAINTENANCE

⚠ CAUTION Always make sure machine is unplugged before lifting electric cover assembly

Item	Procedure
Floor Squeegee	<ul style="list-style-type: none"> • Check condition of squeegee blades and wheels on the floor tool. • Rough floor surfaces will cause the blades and wheels to wear out more quickly. Replace as necessary
Spray Gun	<ul style="list-style-type: none"> • Check spray pattern. If spray pattern will not pinpoint, clean orifice by removing it with an Allen wrench and flushing. Replace if needed. • If nozzle becomes difficult to move from high to low pressure lubricate nozzle with lithium grease.
Pressure Hose	<ul style="list-style-type: none"> • Wipe clean after each use. • Check for cuts or frays in the hose jacket, particularly at the end of the fittings. Replace hose if cuts are found
Water Tank	<ul style="list-style-type: none"> • Check condition of filter in water tank. Clean as needed. • Empty the water tank to prevent mildew and bacteria growth. Empty tank by dipping the vacuum hose into the water tank and transferring the water to the vacuum tank.
Vacuum Tank	<ul style="list-style-type: none"> • Empty and flush vacuum tank. • Clean and disinfect. • Check the float shutoff screen to be sure it is not plugged up. A plugged filter screen restricts airflow and results in reduced suction.
Leaks	<ul style="list-style-type: none"> • Be alert for leaks around hoses, fittings, spray wand, tanks or elsewhere. • Discontinue use until leaks are repaired
Electrical System	<ul style="list-style-type: none"> • The ground fault circuit interrupter (GFCI) must be tested before each use. • Electric cord must be inspected for tears or cuts in the insulation.
Vacuum Wand	<ul style="list-style-type: none"> • Use a wire brush or coarse brush with acid cleaner or other to remove residue from threads on the coupling and coupling nut. Apply grease when done.
HEPA Filter	<ul style="list-style-type: none"> • Replace every 3-6 months depending on use

3.2 BLACK BOX REMOVAL INSTRUCTIONS

1



Remove all hoses, cords, and tools prior to black box removal.

2

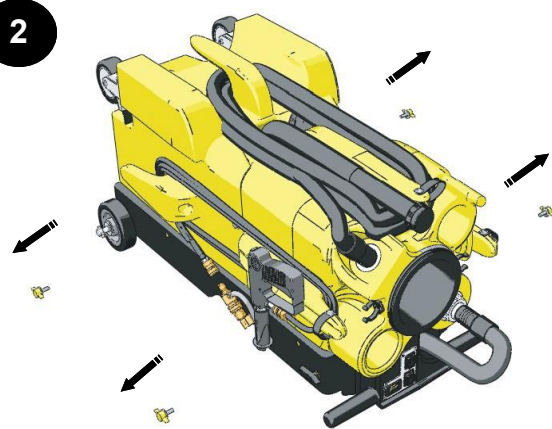

Laying the machine on its back remove the four yellow wingbolts as shown above

3

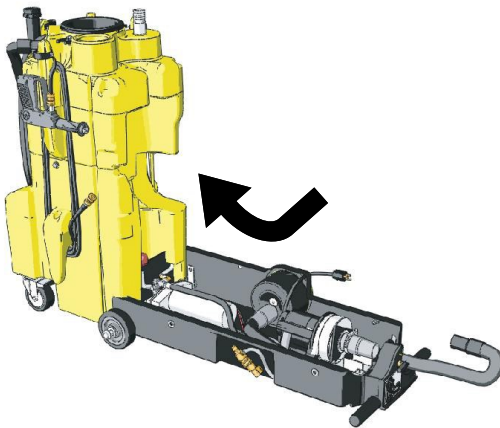

Placing your foot on one of the two handles, tilt the yellow tanks upward until standing upright

4

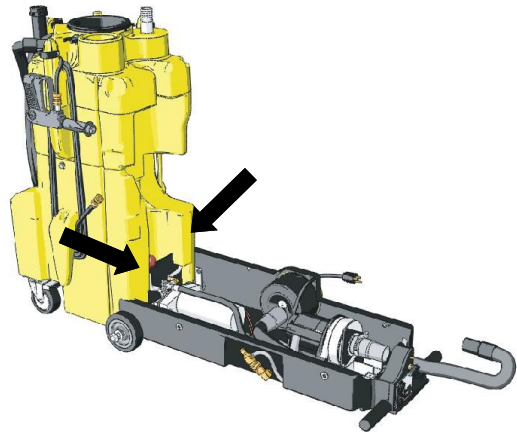

Locate and disconnect the water line and return line behind the black box on the machine

3.3 TROUBLESHOOTING

▲ CAUTION Always make sure machine's unplugged before lifting electric cover assembly

Area	Problem	Possible Cause	Solution
Electrical	No Power to pump or vac motor	Machine not plugged in	Plug machine in
		Switch not "on"	Check switches for "on"
		GFCI tripped	Test and reset GFCI
		Building circuit overloaded	Check and reset circuit
		Switch wires loose	Disconnect power and check for loose wire
		Connections loose	Disconnect Power and check for loose wire under panel
	Electrical burning smell	Vac motor brushes worn	Remove vac motor and repair
		Vac motor hung up	Release pressure on hose and jog vac switch, or replace
		Pump motor hung up	Release pressure on hose and jog pump switch, or replace
Vacuum System	No / Weak vacuum	Vac tank full	Empty vac tank
		Squeegee blades or wheels worn	Replace wheels or blades and check periodically
		Float shutoff screen dirty	Spray off float screen to clean
		Float ball stuck	Tap float and release/clean
		Damaged hose	Cut and repair/replace
		Dump hose plug missing	Contact dealer and replace
		Access lid not tight	Tighten lid hand tight
		Vacuum hose plugged	Flush hose to remove debris
		Too much liquid in vac hose	Allow air in when vacuuming
		Vac hose still wrapped	Unwrap vac hose fully
		Exhaust plugged	Remove HEPA filter and clean
		Leak in vac tank	If repairable, clean and dry affected area and seal with silicone
		HEPA Filter clogged	Remove HEPA filter and clean
		Moisture from exhaust	Vac tank full
	Float shutoff missing		Replace
Excessive foam in vac tank	Use defoamer		
Blow Dry System	No air flow	Hose disconnected	Reconnect hose
	Moisture from nozzle	Water in blow hose	Dry blow line
	Suction, not blow action	Vacuum hose connected to vac tank	Reconnect to vac motor exhaust hose

Area	Problem	Possible Cause	Solution
High Pressure System	No water from pump or low pressure	Out of Water	Fill water tank
		Gun nozzle plugged	Remove orifice with Allen wrench and clean
		Air in pump (vapor lock)	Use power prime technique
		Gun orifice missing	Replace orifice
		Water tank filter plugged	Clean tank and filter
		In - line bowl filter plugged	Remove filter cover and clean
		Bowl filter lid loose	Gently tighten bowl cover
		Pressure hose damaged	Repair or replace
		Quick disconnect leaking	Tighten or replace
		Injector plugged	Remove safety cap from chemical and blow small amounts of compressed air into line
		Pulse hose damaged	Repair or replace
		Regulator failed	Replace
		Hose kinked	Unkink and check for damage
		Seals in pump need re-placed	Remove and replace seals
	Bad fan pattern or pinpoint pattern on gun	Debris in nozzle	Remove orifice with Allen wrench and clean
Orifice damaged		Remove and replace	
Chemical Injection System	No chemical flow	Out of chemical	Refill chemical
		Safety cap not secure	Check safety cap / tighten
		Chemical valve "off"	Check on / off valve
		Safety cap plugged	Replace cap
		Spray gun in wrong mode	Make sure gun nozzle is pulled out away from gun chemical mode
		Metering tip plugged	Check metering tip for clog
		Injector plugged	Remove safety cap from chemical and blow small amounts of compressed air into line
		Air entering system	Check for air entering system around chemical lines or injector
		Injector installed backwards	If fluttering or pulsing sound can be heard while spraying or when machine is running it is possible that your injector is in backwards. Remove and reinstall
		Kink in Chemical line	Replace Chemical line

Area	Problem	Possible Cause	Solution
Chemical Injection System continued	Not enough chemical	Metering tip plugged	Remove and clean
		Wrong metering tip	Check and replace per chart
	Chemical line blows off safety cap	Debris in injector	Remove safety cap from chemical and blow small amounts of compressed air into line
		Water back flows into chemical bottle	Bad seat on injector check valve
Dump System	Dump hose will not empty tank	Bad safety cap	Replace safety cap
		Dump hose cap not removed	Remove cap
	Dump hose leaks	Clog in bottom of tank	Tip dump contents, remove debris
		Hose cut	If leak is less than 4" from tank side, cut and reattach, or replace
		Clamp loose	Tighten hose clamp
Dump cap missing	Replace cap		
Wheels and Casters	Wheels won't roll, or they rub	Flat tires	Inflate tires to 30 p. s. i.
		Debris wrapped around axle	Check for debris on axle
		Bearings tight	Grease bearings
		Wheels too loose on axle	Remove wheel, add washers to take up slack
		Bearings falling out	Replace bearing assembly
Squeegee Head	Floor streaks	Worn blades or wheels	Replace wheels and / or blades
	Squeegee head doesn't easily rotate when installed on wand	Brass ring on wand not in groove	Loosen coupling nut and re-position head on groove
		Coupling nut too tight	Loosen 1 / 2 turn
	Head won't stay on wand	Coupling nut cracked	Replace
		Brass ring worn	Replace
	Premature blade wear	Squeegee wheels worn	Check wheels for wear / replace
Sucks to the floor too tightly	Squeegee wheels worn	Check wheels for wear / replace	

3.4 VACUUM DIAGRAM

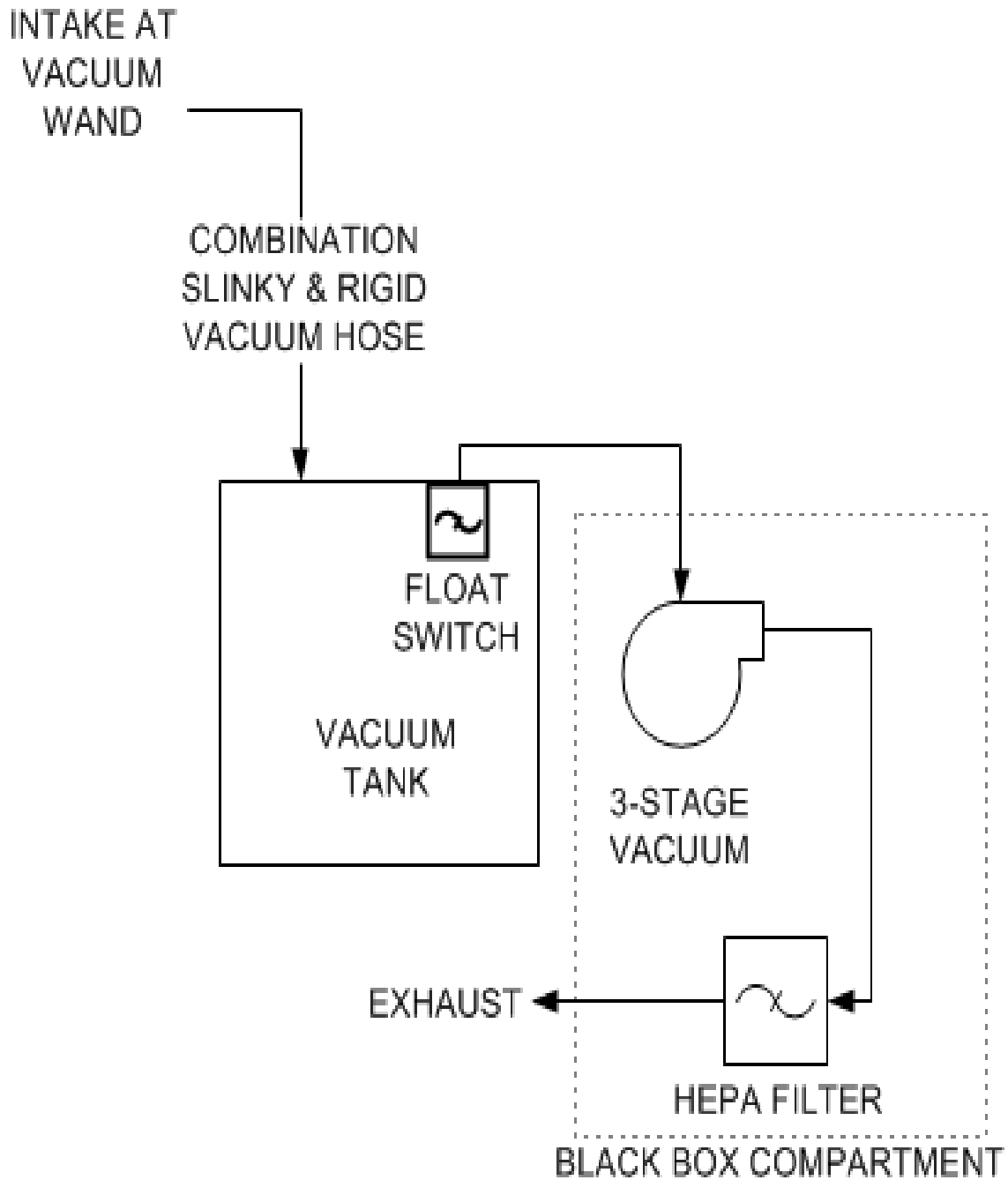

3.4 PUMP DIAGRAM

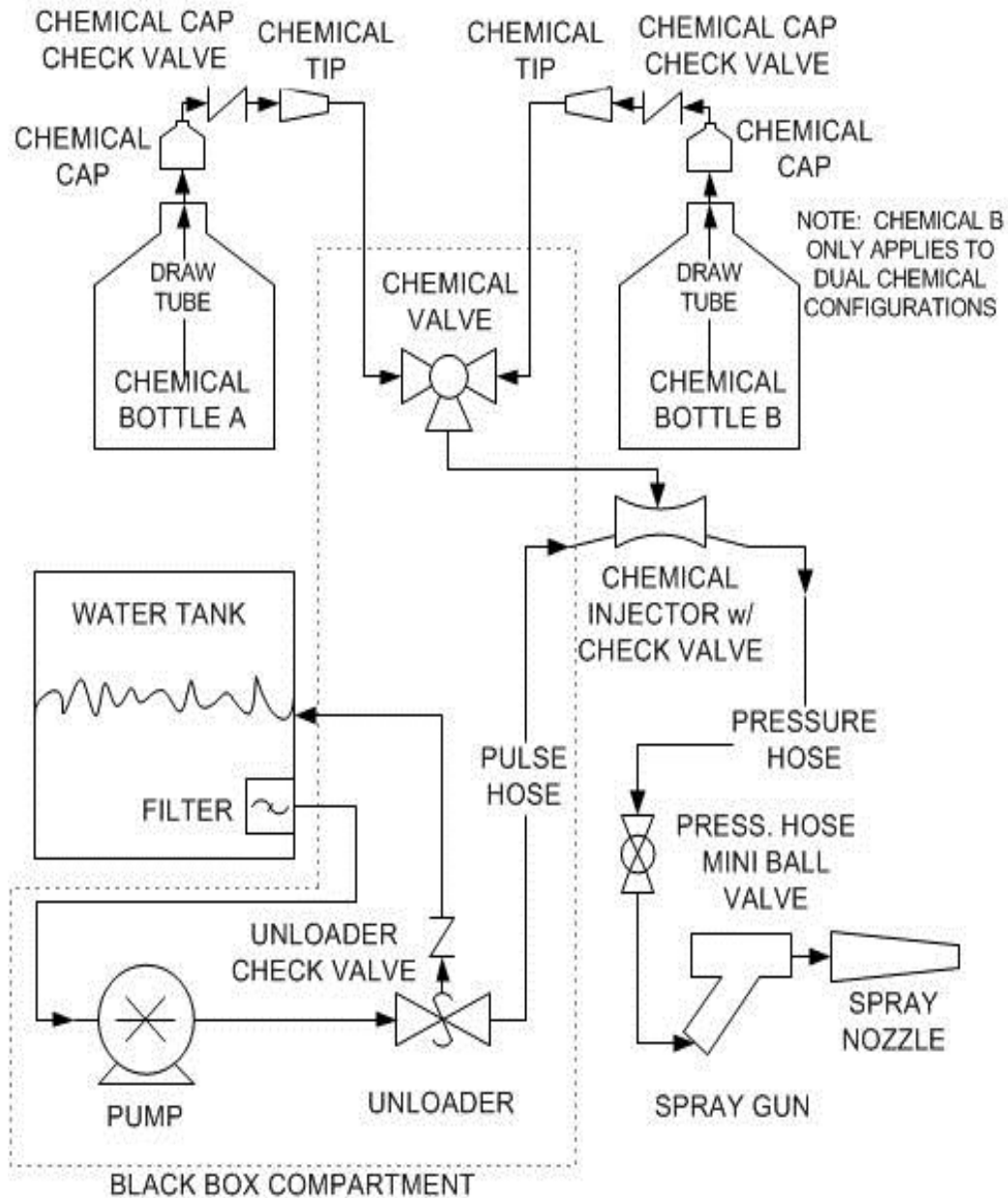

3.4 ELECTRICAL DIAGRAM

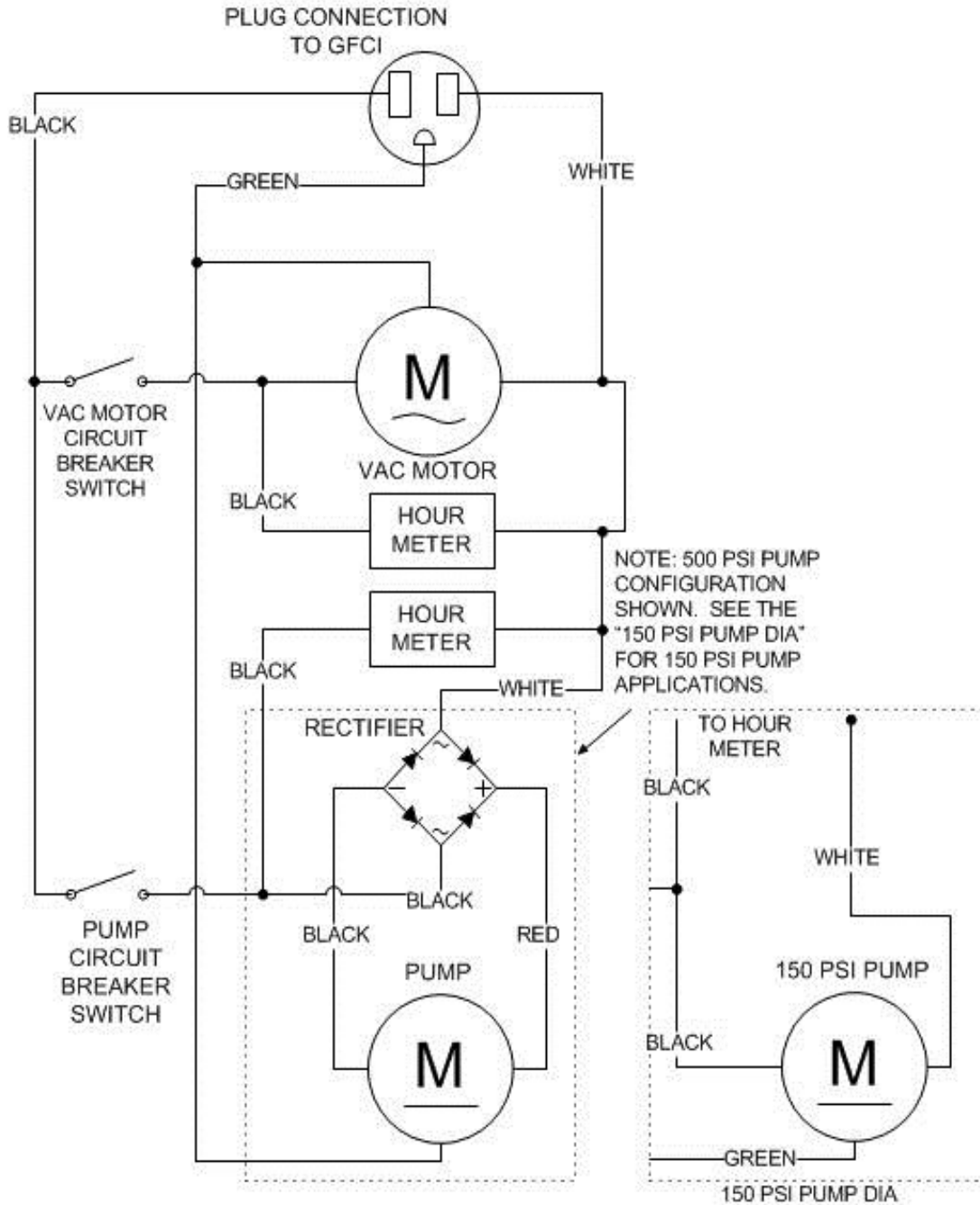

3.4 MACHINE DIAGRAMS

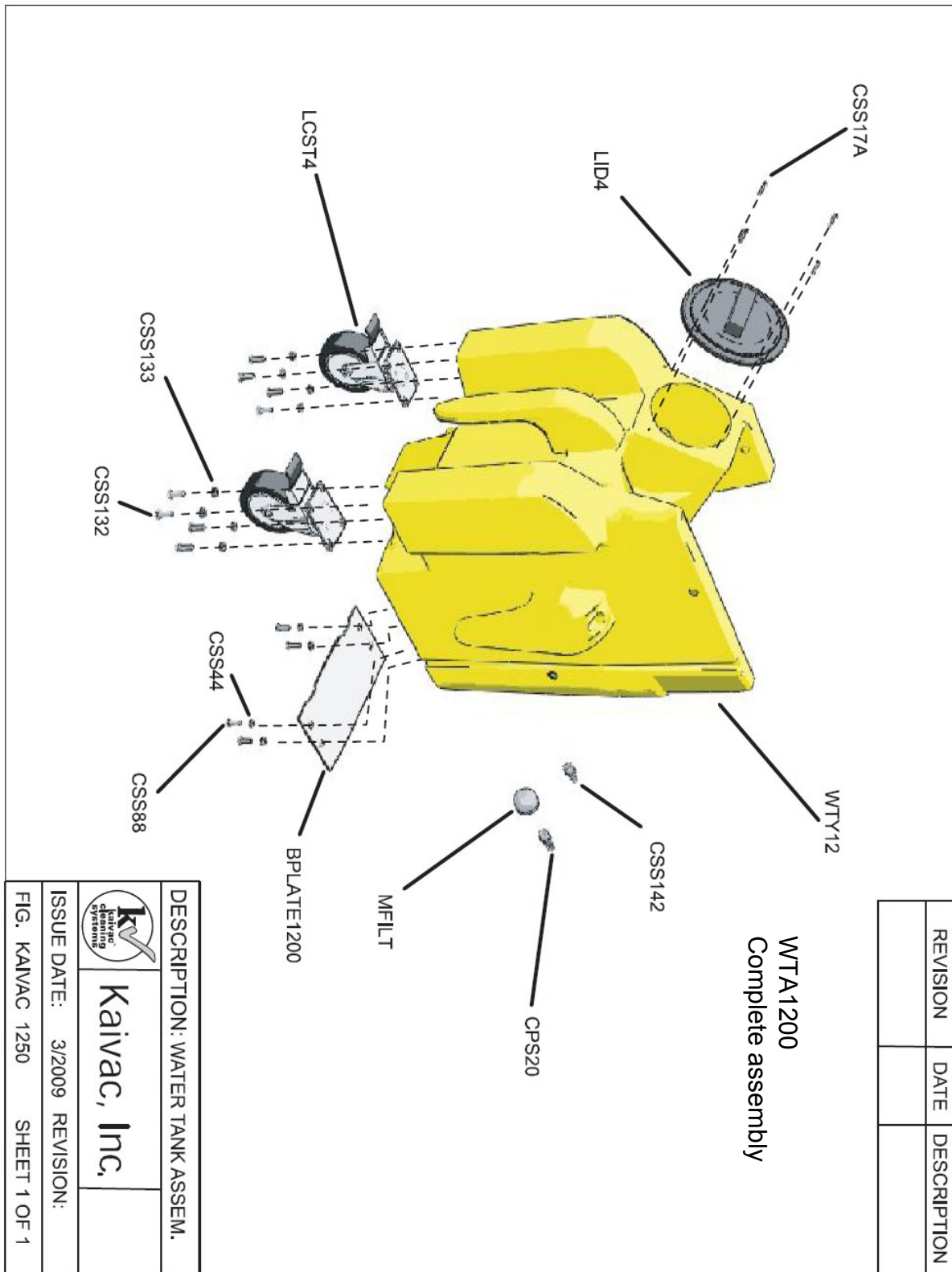

3.4 MACHINE DIAGRAMS

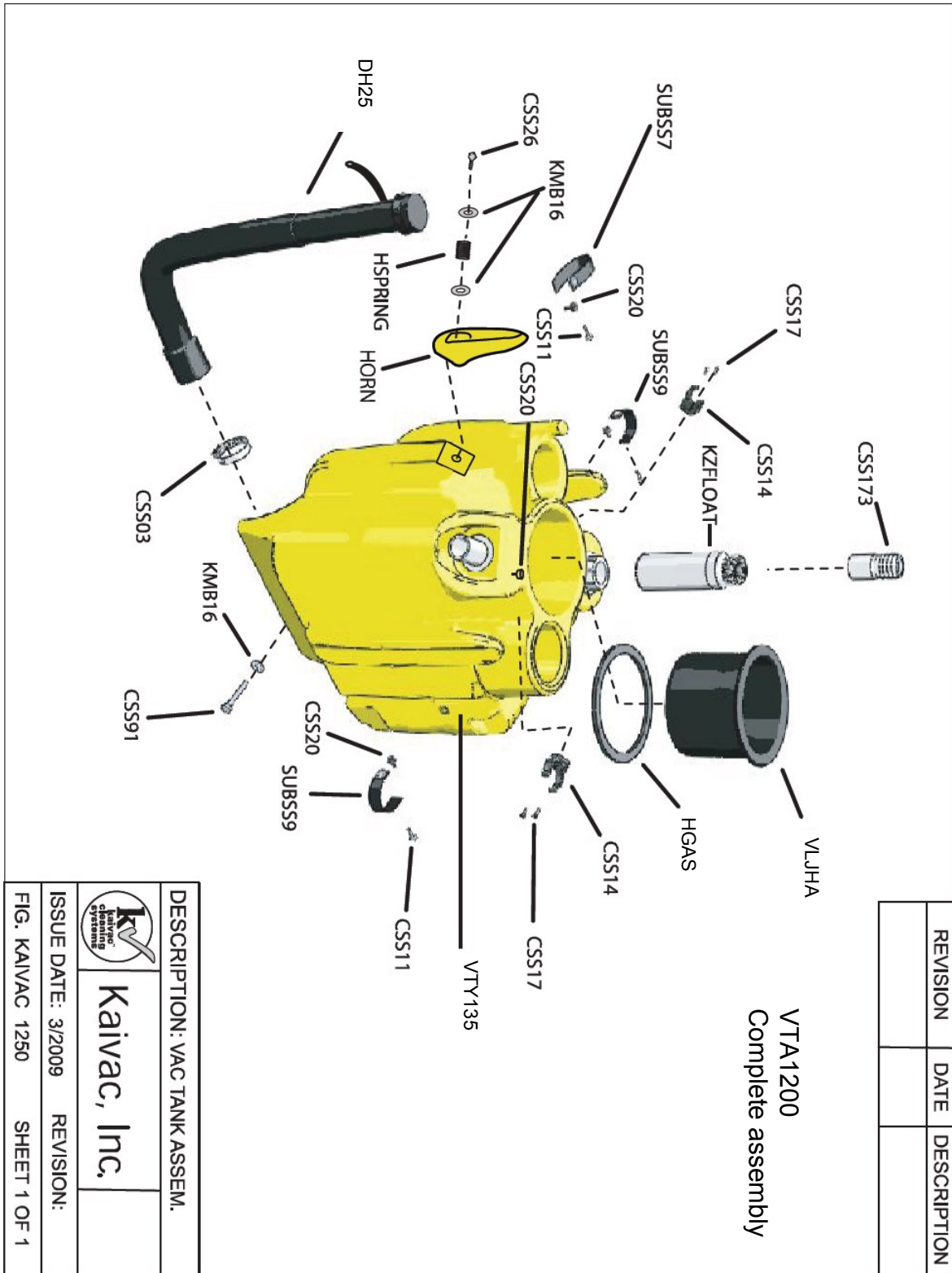

3.4 MACHINE DIAGRAMS

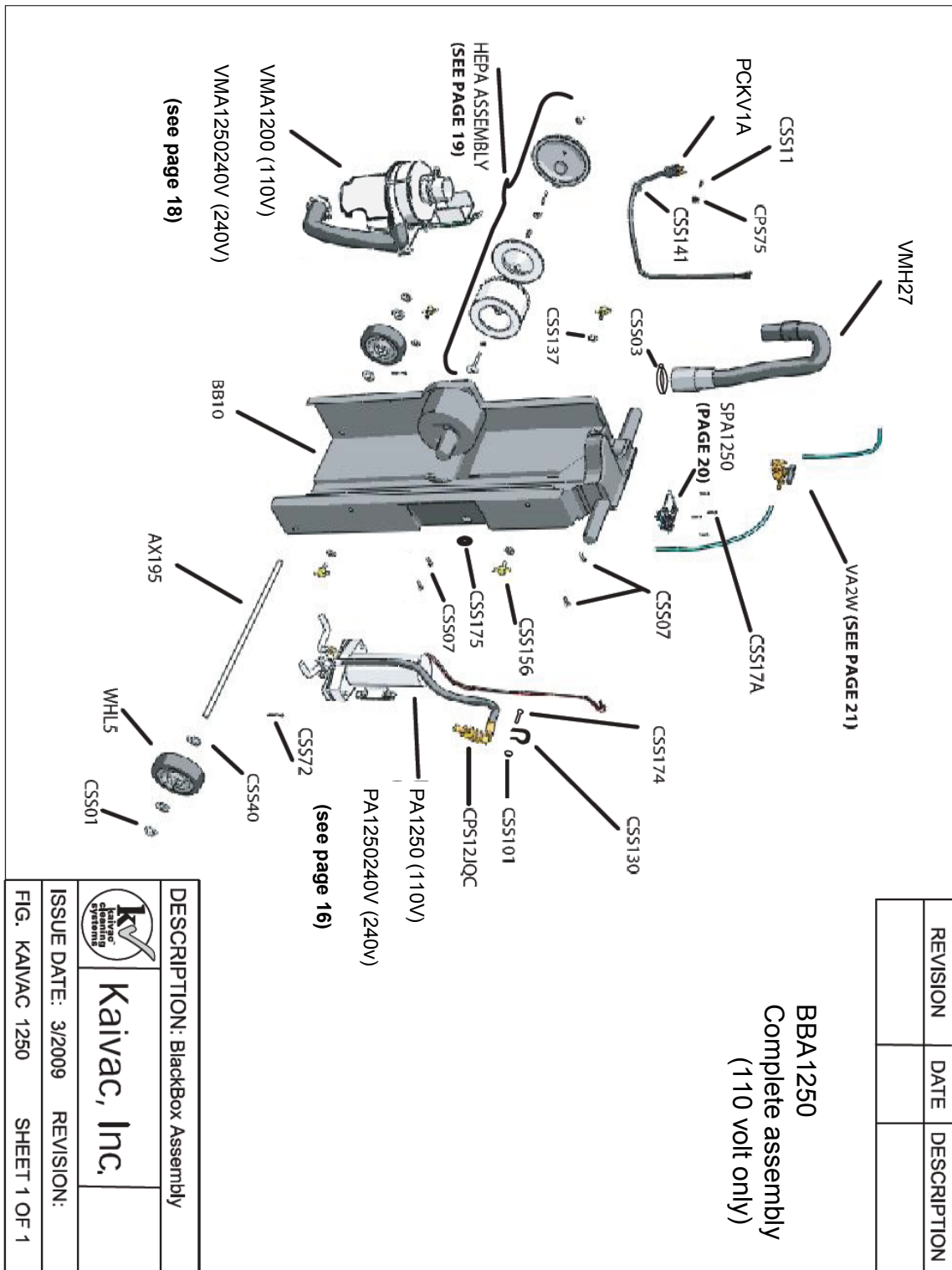

3.4 MACHINE DIAGRAMS

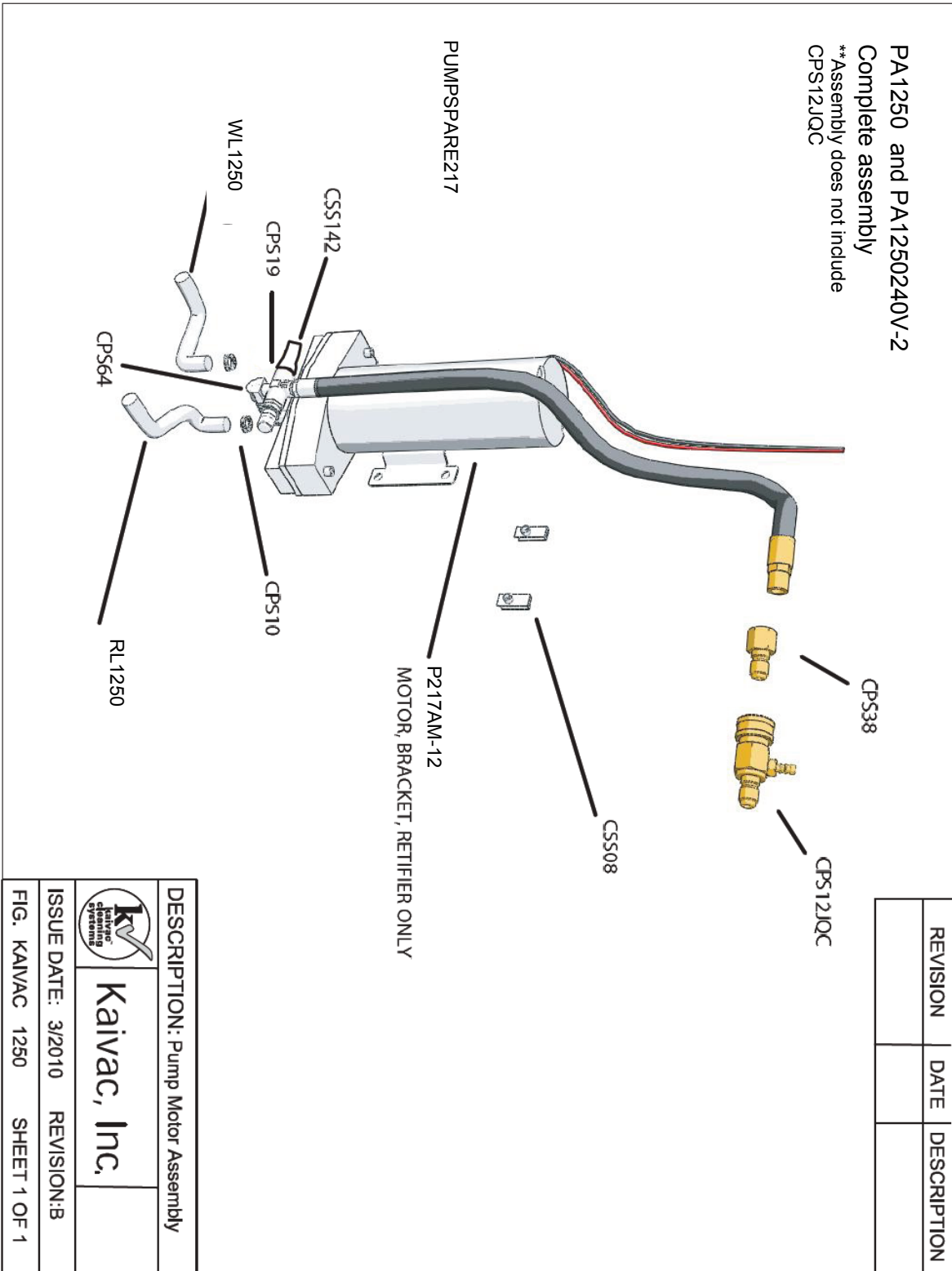

3.4 MACHINE DIAGRAMS

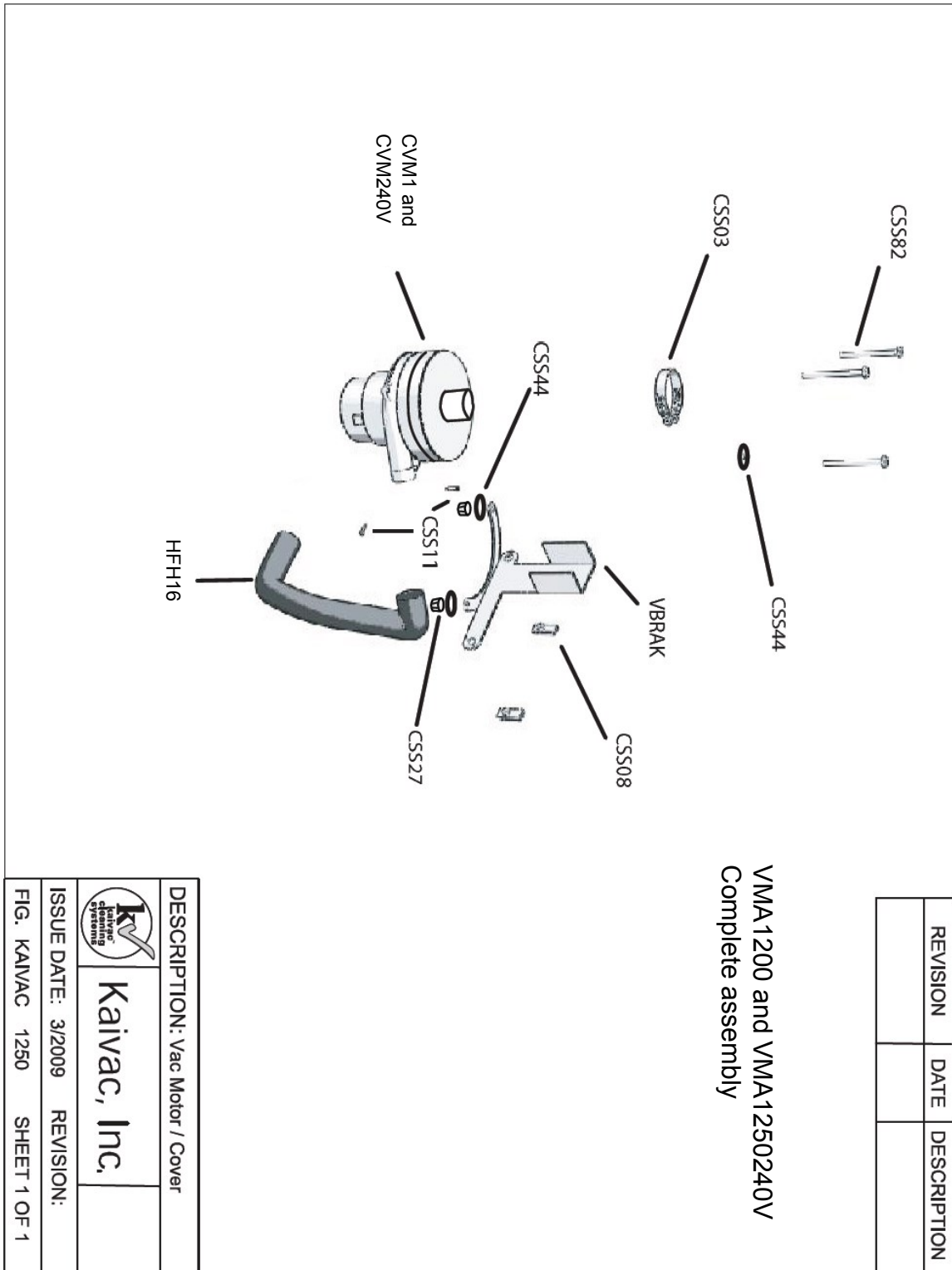

3.4 MACHINE DIAGRAMS

HEPA HOUSING ASSEMBLY (HEPAHA2)

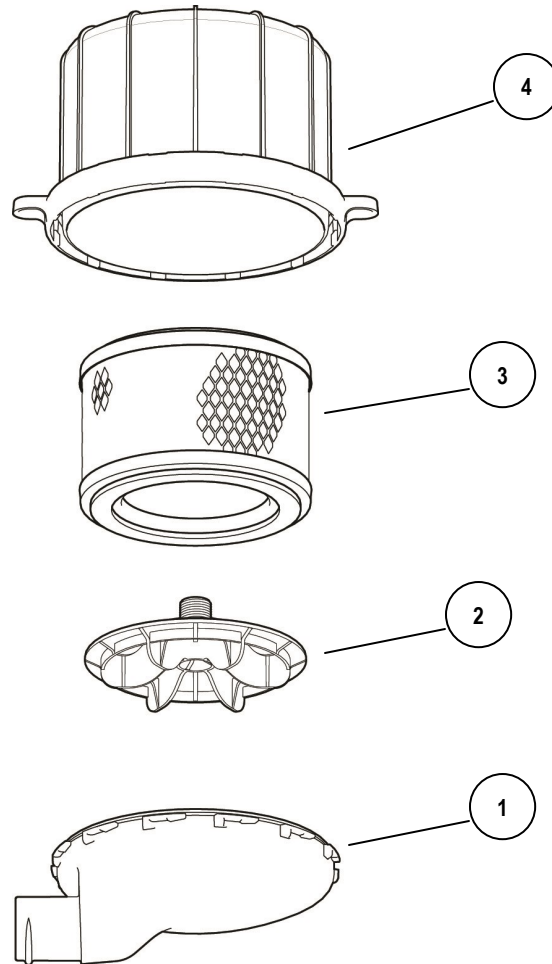

#	PART NO.	PART DESCRIPTION
1	HCOVER	HEPA COVER
2	FKEEP2	HEPA FILTER KEEPER
3	HEPA	HEPA FILTER
4	HEPAH2	HEPA FILTER HOUSING

3.4 MACHINE DIAGRAMS

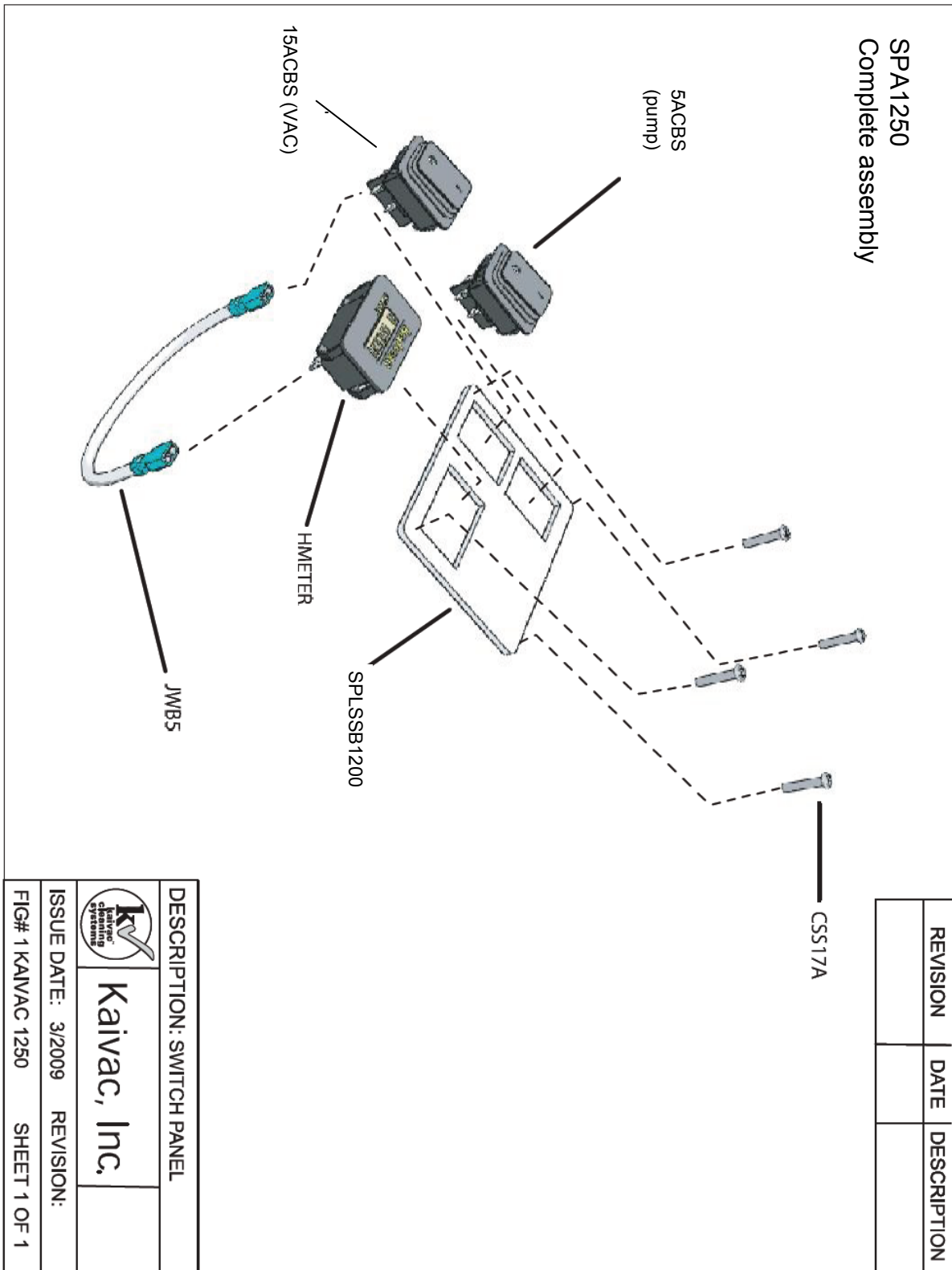

3.4 MACHINE DIAGRAMS

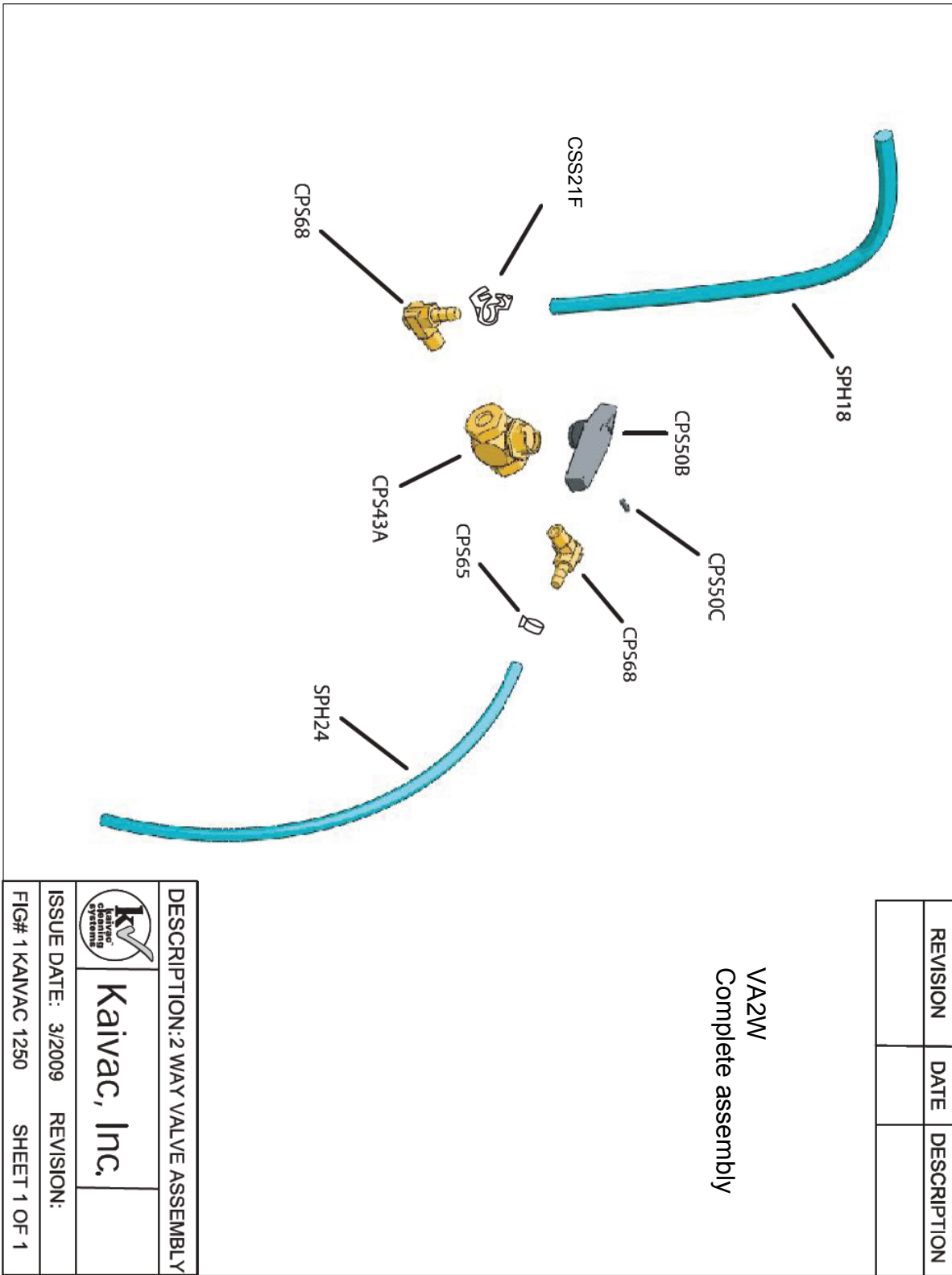

3.4 MACHINE DIAGRAMS

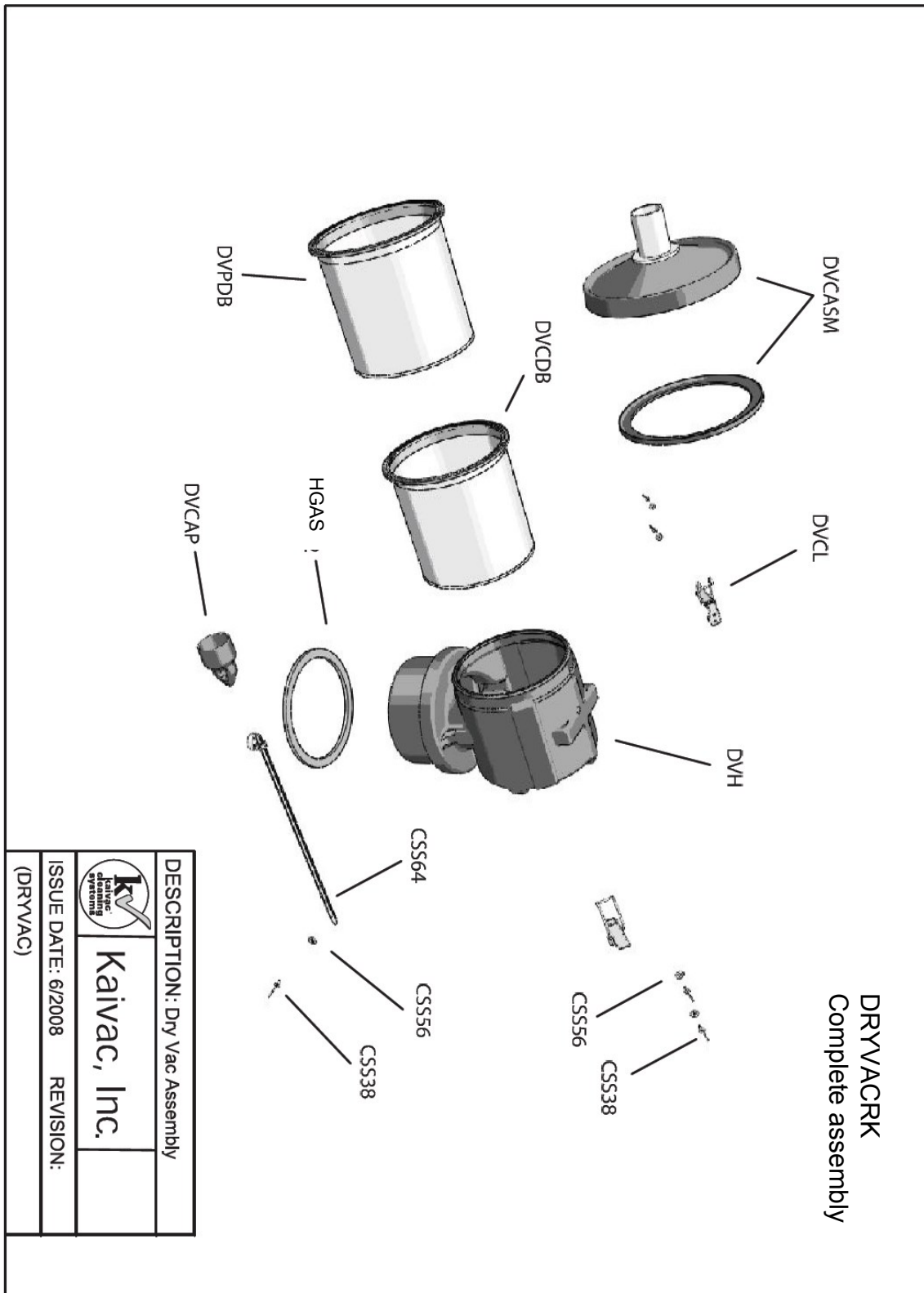

3.5 PARTS LIST

PART NUMBER - DESCRIPTION	QTY
WATER TANK ASSEMBLY (WTA1200)	1
WTY12 - WATER TANK YELLOW 12 LBS 1200 S ASSEM	1
CPS20 - 3/8 X 1/2 HOSE BARB	1
CSS142 - 3/8 INCH BRASS HOSE BARB	1
MFILT - MUSHROOM FILTER	1
LID4 - LID WITH TETHER 4 1/4 IN	1
CSS17A - 8 SST SCREW 3/4	4
CSS11 - NO 10 X 3/4 SELF DRILLING	1
LCST4 - 4 TOTAL LOCK CASTER	2
CSS133 - 5/16 SPLIT LOCK WASHER 300 SS	8
CSS132 - 5/16-18X1 BUTTON HEAD	8
GR2 - KV LOGO STICKER	2
CSS14 - 13 CLAMP , FOR TOOLS	1
CSS17 - NO 8 FLAT HEAD SQUARE SCREW	2
FLAGLAB - ASSEMBLED IN AMERICA FLAG LABEL	1
VAC TANK ASSEMBLY (VTA1200)	1
VTY135 - VAC TANK YELLOW 13.5 LBS 1200 S ASSEM	1
KZFLOAT - FLOAT SHUT OFF	1
CSS173 - 1 1/4 NPT X 1 1/2 HOSE ADAPTER	1
DH25 - 26" X 1.5" DUMP HOSE 2" CUFF	1
CSS03 - 1 9/16 - 2 1/2 HOSE CLAMP	1
CSS14 - 13 CLAMP , FOR TOOLS	2
CSS17 - NO 8 FLAT HEAD SQUARE SCREW	4
SUBSS9 - 9 IN. SNAP AND STRAP	2
SUBSS7 - 7 IN SNAP AND STRAP	1
CSS20 - SNAP STUD	5
CSS11 - NO 10 X 3/4 SELF DRILLING	3
CSS91 - 3/8 X 2 1/4 BOLT	2
KMB16 - 3/8 SST FLAT WASHER	2
CSS58 - 3/8 X 16 X 1 SST SCREW	1
CSS48 - 3/8 SST LARGE OD WASHER	1
FIG8LABEL - FIGURE 8 LABEL 1-1/4 X 3-1/4	1
VAC LID, JUG HOLDER ASSEM (VLJHA)	
VLJH - VAC LID , JUG HOLDER	1
HGAS - HEPA BLOW COVER GASKET	1

3.5 PARTS LIST

PART NUMBER - DESCRIPTION	QTY
BLACK BOX ASSEMBLY (BBA1250)	1
BB10 - BLACK BOX 1200 S 10 LB ASSEMBLY	1
CSS200 - ADHESIVE CABLE CLAMP	2
AX195 - AXLE 19.75 X 1/2 CR STEEL	1
WHL5 - 5 X 1 1/2 TPU WHEEL W-1/2 BB	2
CSS40 - 1/2 DIA WASHERS	6
CSS72 - COTTER PIN 1/8 DIA X 1 1/4 LG	2
CSS01 - 1/2 IN PUSH CAP NUT	2
VMA1200—VAC MOTOR ASY (110V)	
VMA1250240V—VAC MOTOR ASY (240V)	1
PA1250 - PUMP ASSEM FOR KV1250	
PA1250240V-2—PUMP ASSEM FOR (240V)	1
CSS07 - 5/16-18 X 1 HEX HEAD	4
CSS136 - 6 NATURAL CABLE TIE	1
CSS175 - 3/4 ID X 1 3/8 OD GROMMET	1
CSS130 - RUBBER CUSHIONED STEEL LOOP	1
CSS174 - 1/4-20 X 5/8 MACHINE SCREW SS	1
CSS101 - ACORN NUT 1/4 20	1
PCKV1A - 22 IN. POWER CORD WITH MOLDED	1
CPS75 - CABLE CLAMP FOR EXT. CORD	2
CSS11 - NO 10 X 3/4 SELF DRILLING	2
CSS17A - 8 SST SCREW 3/4	2
HEPAHA2 - HEPA HOUSING ASSEMBLY	1
HEPALAB - HEPA WARNING LABEL	1
VA2W - VALVE ASSEM 2 WAY FOR KV1250	1
SPA1250 - SWITCH PANEL ASSEM FOR KV1250	1
CSS17A - 8 SST SCREW 3/4	6
CPS12JQC - QUICK CONNECT INJECTOR	1
CSS21F - SNAP GRIP HOSE CLAMP SIZE C	1
CSS39 - 1 1/16 - 2 HOSE CLAMP	1
SP1250 - SERIAL PLATE FOR KV1250	1
SERIALLABEL - SERIAL NUMBER LABEL	2
NFSIL - NFSI LABEL	1
CSS308 - 1200 BLACK BOX HOSE HOOK	1
CSS48 - 3/8 SST LARGE OD WASHER	1
CSS54 - 3/8 HEX NUT	1
CSS127 - QUICK DISCONNECT TERMINAL	1
OMLAB2 - OMNIFLEX MAINTENANCE LABEL BLADES	1

3.5 PARTS LIST

PART NUMBER - DESCRIPTION	QTY
1250 PUMP ASSEMBLY (PA1250 (110V) PA1250240V-2 (240V)	1
P217AM-12 - 1250 PUMP SERIES 217V-110/M9253F	
PUMP217240VDC - 240V DC PUMP	1
WL1250 - WATER LINE FOR KV1250	1
RL1750 - RETURN LINE FOR 1750	1
CSS08 - 5/16-18 U-NUT	2
JWW - JUMPER WIRE WHITE 12 IN	1
JWB - JUMPER WIRE BLACK 12 IN	1
CSS127 - QUICK DISCONNECT TERMINAL	1
CSS64 - TIE WRAP FOR FILTERS	1
CPS10 - 7/16 - 25/32 HOSE CLAMP	2
VAC MOTOR ASSEMBLY (VMA1200)(110V) VMA1250240V (240V)	1
CVM1 - MOTOR FOR BUILDS--REPLACEMENTS- USE CVM1R	1
CES24 - 16 GAUGE BLACK WIRE	0.5
CSS127 - QUICK DISCONNECT TERMINAL	1
CES27 - 16-14 GAUGE BUTT SPLICES	1
HFH16 - HEPA FILTER HOSE 16 IN FOR	1
CSS39 - 1 1/16 - 2 HOSE CLAMP	1
CSS11 - NO 10 X 3/4 SELF DRILLING	2
VBRAK - VAC MOTOR BRACKET KV1200	1
CSS44 - 1/4 FLAT WASHER	2
CSS27 - 1/4 NYLOC NUT	2
CSS203 - HEX HEAD BOLT 1/4 20 X 1 1/4	2
CSS08 - 5/16-18 U-NUT	2
VMH27 - VAC MOTOR HOSE NEW	1
VALVE ASSEM 2 WAY FOR KV1250 (VA2W)	
CPS43A - 2 WAY BRASS VALVE VITON SEALS	1
CPS68 - 90 DEG. 1/8 NPT MALE X	2
CPS65 - 1/2 IN CLAMP	1
CSS21F - SNAP GRIP HOSE CLAMP SIZE C	1
SPH18 - 2 WAY VALVE HOSE FOR KV1250	1
SPH24 - ELEC BOX CHEMICAL HOSE 24 IN	1

3.5 PARTS LIST

PART NUMBER - DESCRIPTION	QTY
1200 SERIES SWITCH PANEL ASSEMBLY (SPA1250)	1
HMETER - SNAP IN DIGITAL HOUR METER	1
JWB5 - JUMPER WIRE BLACK 5 IN	1
CSS123 - QUICK CONNECT PIGGY BACK TERM	1
SPLSSB1200 - SWITCH PLATE SS W/ BREAKER	1
15ACBS - 15 AMP CIRCUIT BREAKER SWITCH	1
5ACBS - 5 AMP CIRCUIT BREAKER SWITCH	1
STANDARD ACCESSORIES 1200 SERIES	
BPLATE1200 - BOTTOM PLATE FOR 1200 SERIES	1
CSS88 - 1/4-20 X 3/4 SST SCREW	4
CSS44 - 1/4 FLAT WASHER	4
CSS156 - 3/8 X 3/4 T THUMB SCREW YELLOW	3
CSS48 - 3/8 SST LARGE OD WASHER	3
CPS65 - 1/2 IN CLAMP	1
GFCI25 - GFCI 25 FT (110V ONLY)	1
PH45 - PRESSURE HOSE ASSEM 45 FT	1
SUBGAKW - PRESSURE GUN GREEN DOT (110V)	1
MTIPSNEW - METERING TIP PACK	1
CHCAPA - CHEM CAP W/SAFETY CHECK VALVE AND SCREEN	1
1250ACC - 1250 ACCESSORY KIT	1
UFH - UNIVERSAL FILL HOSE	1

3.5 PARTS LIST

PART NUMBER - DESCRIPTION	QTY
1250 ACCESSORY KIT (1250ACC)	
VHST45 - 45 FT STRETCH HOSE 5 TO 1 RATIO	1
DRWED - DOOR WEDGIE	1
TBAG - TOTE BAG	1
OFVWGB - VAC WAND W/ CLIP, STRAP & GRTBRUSH	1
VBRUSH - SQUEEGEE HEAD BRUSH COMPLETE	1
CVS12S - 14.5 SQUEEGEE HEAD WITH SS WHEELS	1
CVS13 - BLOW NOZZLE	1
CAA06 - WINDOW SQUEEGEE COMPLETE	1
CVS14 - KRIDRAIN GULPER TOOL	1
SUBBLHSST - 33 FT BLOW HOSE	1
QS1200 - QUICK START FOR KV1200 SERIES	1
MANUAL1200 - MANUAL FOR 1200 SERIES	1
KTDVD - KAITUTOR TRAINING DVD DISK	1
PLCRD - PLACARD FOR 1200 1700 2100 UNITS	1
STF - SMART TOWEL FLYER	1
12ACCBX - 24 1/4 X 20 1/4 X 6 1200 ACCESSORY BOX	1
1215 ACCESSORY KIT (1215ACC)	
VHKVJRST - BLACK STRETCH VAC HOSE W/ BLACK CUFFS	1
OFVWGB - VAC WAND W/ CLIP, STRAP & GRTBRUSH	1
VBRUSH - SQUEEGEE HEAD BRUSH COMPLETE	1
QS1200 - QUICK START FOR KV1200 SERIES	1
KTDVD - KAITUTOR TRAINING DVD DISK	1
MANUAL1200 - KAIKAC 1215 MANUAL	1
STF - SMART TOWEL FLYER	1
12ACCBX - 24 1/4 X 20 1/4 X 6 1200 ACCESSORY BOX	1